



Mobile Wash Station

The Mobile Wash Station from Stoddart Manufacturing is the culmination of years of experience in manufacturing and supplying convention centres and stadiums throughout Australia.

This product is designed to be easy to operate and maintain. Attention to detail is focused on, providing optimum hygiene and safety.

Models:

SPPL.WB.MWS.xxxx.yyyy

Code explanation:

SPPL = Standard Product Plumbing

WB = Wash Basin

MWS = Mobile Wash Station

xxxx = Unit length

yyyy = Unit Width

e.g.: for specification and ordering

SPPL.WB.MWS.1370.760

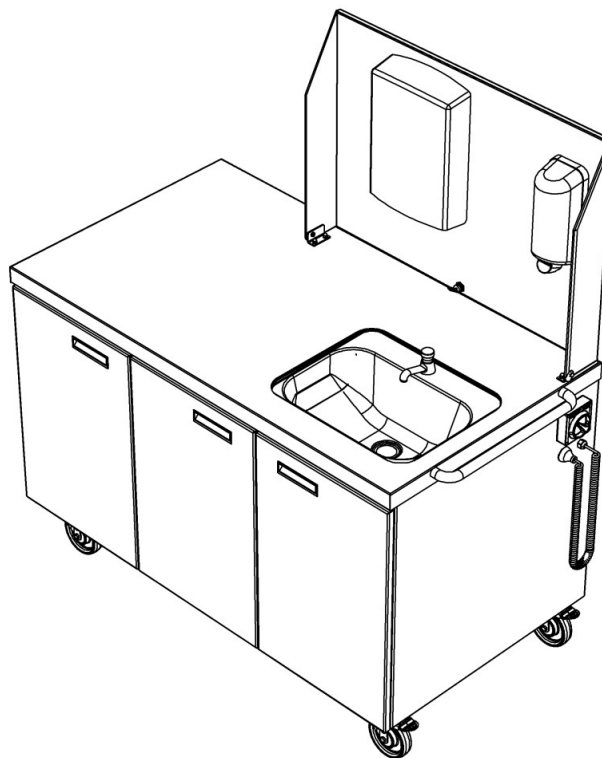

Features and Benefits:

- Instant tempered water available through on board heating system.
- Large 125mm non-marking castors for ease of mobility.
- Ezy Push timed flow tap for convenient hand wash operation.
- Self priming pump from easy fill 20L storage tank and onboard drainage tank.
- Fold down splashback with integrated soap and towel dispensers.
- 15 Amp flexi cord supplied with its own location socket for mobility.
- Stainless steel push handle.
- Storage cupboard under, complete with fixed shelf.



Due to continuous product research and development, the information contained herein is subject to change without notification.



Mobile Wash Station

Specifications:

Construction: Fully welded 304 grade stainless steel construction bench top and basin, no 4 brushed finish.

Models:

SPPL.WB.MWS.xxxx.yyyy

Code explanation:

SPPL = Standard Product Plumbing

WB = Wash Basin

MWS = Mobile Wash Station

xxxx = Unit length

yyyy = Unit Width

e.g.: for specification and ordering

SPPL.WB.MWS.1370.760

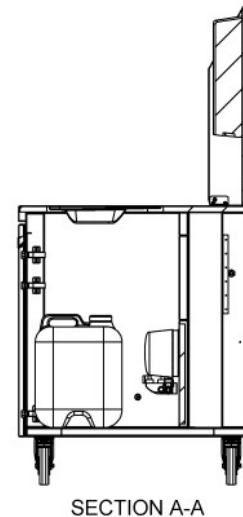
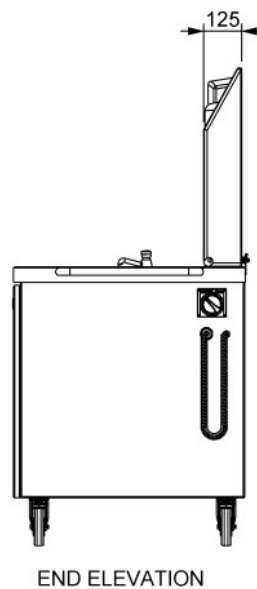
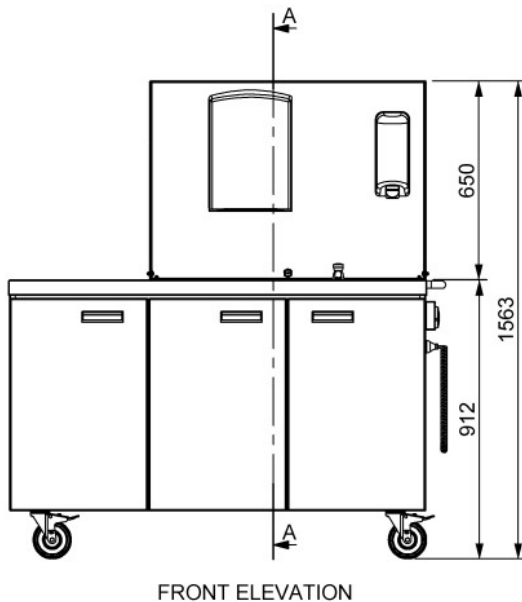
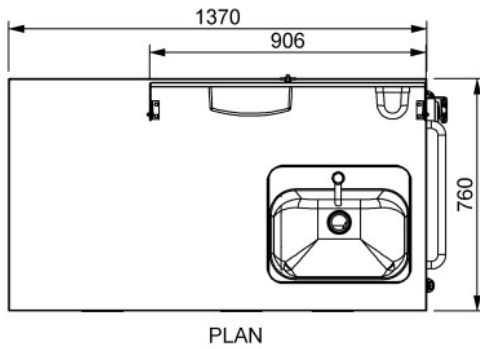

Model No.	Length (mm)	Width (mm)	Height (mm)
SPPL.WB.MWS.xxxx.yyyy	xxxx	yyyy	914 (1564 with splashback)

Due to continuous product research and development, the information contained herein is subject to change without notification.