



Drinking Fountain Metro

Freestanding

Drinking Fountains for parks and outdoor areas made by Stoddart are branded Metro. Metro Drinking Fountains provide clean fresh drinking water through a safe hygienic drinking bubbler.

The Metro Freestanding Drinking Fountains can be ordered as a single or as a dual fountain unit. The disabled height is also good for children. The Metro design is robust, vandal resistant and easy to install, maintain and use.

Models:

SPPL.DF.Mx.FS

Code explanation:

- SPPL = Standard Product Plumbing
- DF = Drinking Fountain
- Mx = MS – Metro Single (700h)
= MD – Metro Dual (700h & 850h)
- FS = Freestanding

Optional Extras

- DB = Dog Bowl (Hinged)
- BF = Dog Bowl Filler Drain
- BT = Bottle Tap on post
- VAR = Custom Variations

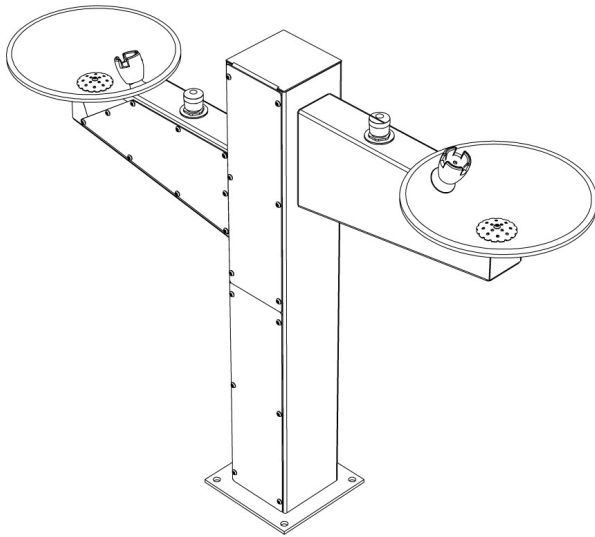

SPPL.DF.MD.FS

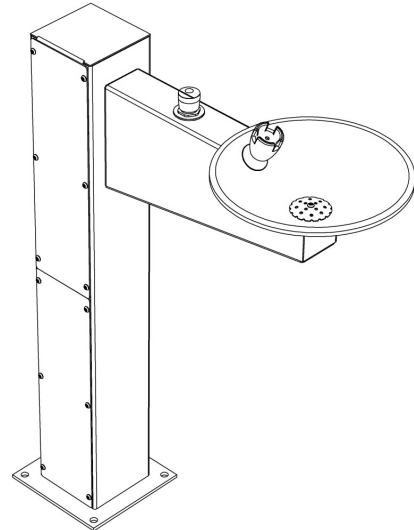

SPPL.DF.MS.FS

Features and Benefits:

- Easy-Push buttons & valves supply a regulated flow of fresh clean drinking water through the safe & hygienic drinking bubblers to make drinking access easy without water wastage.
 - Large round collection bowl prevents excess water from forming mud puddles on the ground.
 - Excess water is drained through the post & can be connected to a rubble pit, a nearby garden bed or, with the addition of a trap, it can be connected to grey water.
 - An optional Dog bowl can be added to the post & excess drinking water can be drained to fill the dog bowl.
 - The Metro Drink Fountain is robust & vandal resistant for outdoor use with plumbing connections access via secure access panels.
- Metro Drink Fountains are corrosion resistant to provide years of trouble free service in marine environments.



Suitable for use where disabled access is required



WaterMark
AS/NZS 3718 Lic. WMKA0034
SAI Global
For Easy Drink Tap



Due to continuous product research and development, the information contained herein is subject to change without notification.



Drinking Fountain Metro

Freestanding

Specifications:

- Construction: Stainless Steel construction, satin finish. Unit is pre plumbed with button & bubbler.
- Water Supply: 15mm (1/2" BSP)
- Waste Connection: 40mm waste connection in post. Excess water is drained through the post & can be connected to a rubble pit, a nearby garden bed or, with the addition of a trap, it can be connected to grey water.
- Unit Fixing: The unit is welded to a 6mm thick stainless steel floor mounting plate with 13mm fixing holes. Drink fountain access plates are fitted to bowl arm and post with 6mm torque screws.

Models:

SPPL.DF.Mx.FS

Code explanation:

- SPPL = Standard Product Plumbing
- DF = Drinking Fountain
- Mx = MS – Metro Single (700h)
= MD – Metro Dual (700h & 850h)
- FS = Freestanding

Optional Extras

- DB = Dog Bowl (Hinged)
- BF = Dog Bowl Filler Drain
- BT = Bottle Tap on post
- VAR = Custom Variations

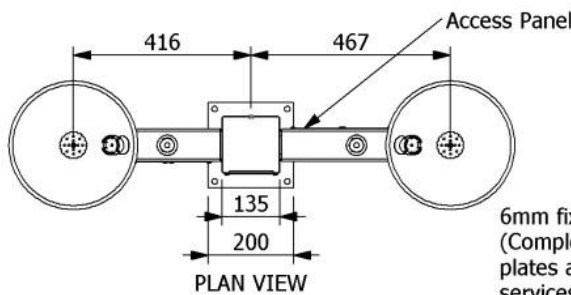

6mm fixing plate
(Complete with 4 of 13Ø fixing plates at 170 centers and 98Ø services hole to centre)

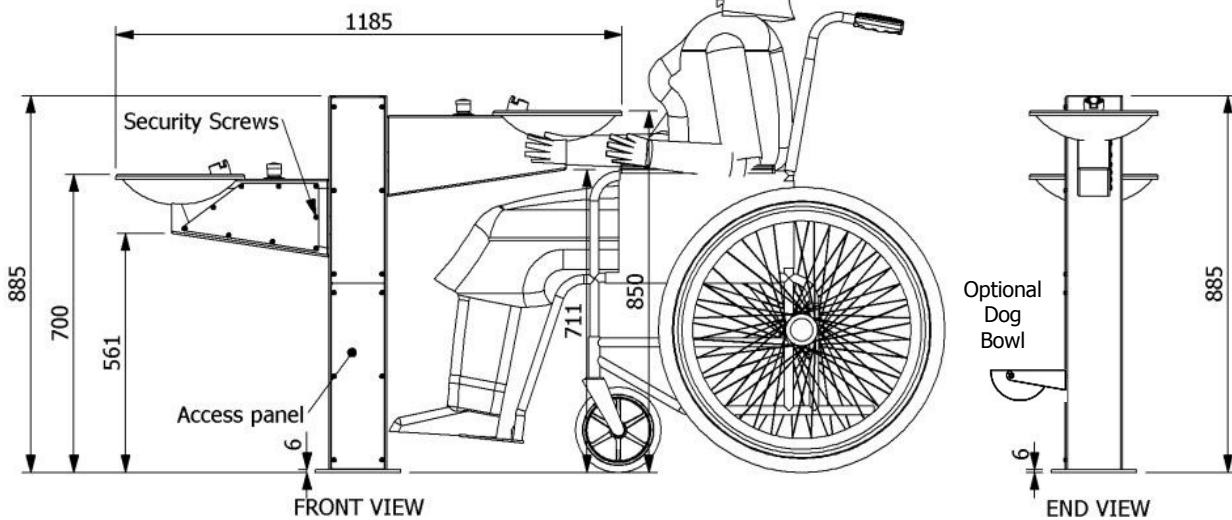
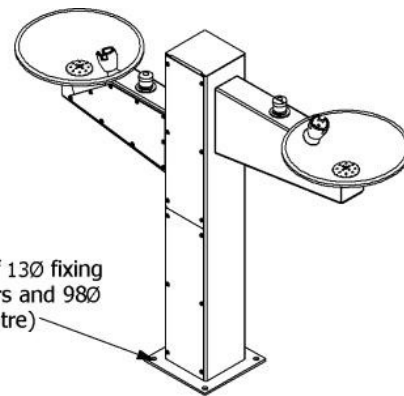

Type	Basin top height (mm)	Clearance to underside (mm)
Standard height	850	717
Disabled height	700	567

Due to continuous product research and development, the information contained herein is subject to change without notification.