

Drinking Fountain Metro Dual

Wall Mounted

Drinking Fountains for Schools, Shopping malls and outdoor areas made by Stoddart are branded Metro. Metro Drinking Fountains provide clean fresh drinking water through a safe hygienic drinking bubbler.

The Stoddart Metro Dual Wall Mounted Drinking Fountain is wall mounted on a robust stainless steel mounting panel and has large front mounted, easy push buttons. It also allows clear access for wheelchair disabled users when mounted at the correct height.

It is robust, vandal resistant and easy to install, maintain and use. The Plumbing is secured & accessed via a large access panel.

Models:

SPPL.DF.MD.WM

Code explanation:

SPPL = Standard Product Plumbing

DF = Drinking Fountain

MD = Metro Dual

WM = Wall mounted

e.g.: for specification and ordering

SPPL.DF.MD.WM

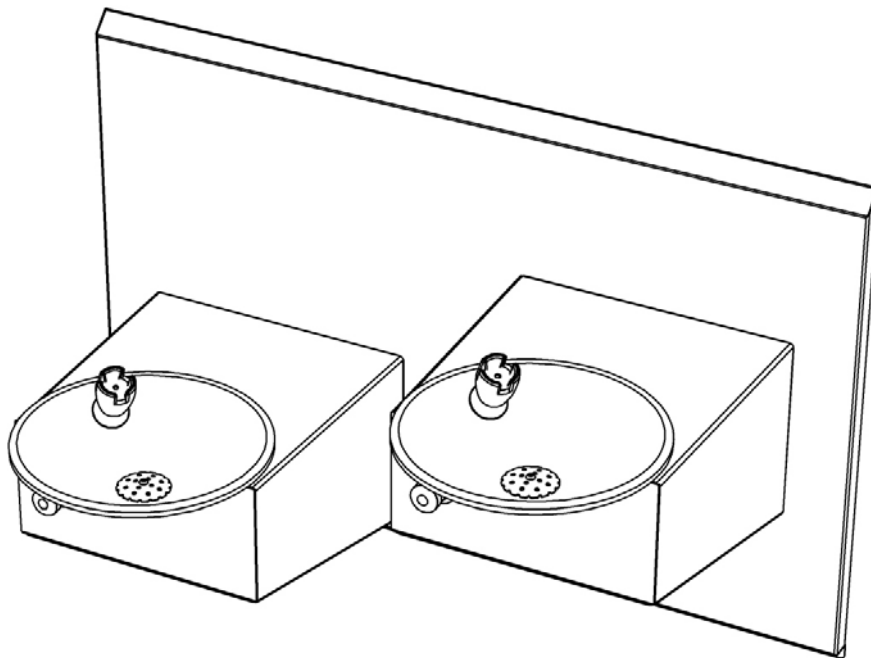

Features and Benefits:

- Easy-Push buttons & valves supply a regulated flow of fresh clean drinking water through the safe & hygienic drinking bubblers to make drinking access easy without water wastage.
- Large round collection bowl prevents excess water from forming mud puddles on the ground.
- Excess water is drained & can be connected to a rubble pit, a nearby garden bed or, with the Hepvo trap, it can be connected to grey water.
- Wall Mounted Drinking Fountain can be easily mounted to most wall surfaces at heights suitable to the application.
- Access for wheel chair disabled users is provided as per the requirements advised in AS1428.2
- This unit can also be configured with a vented wall panel if a chilled water unit is to be fitted.



Suitable for use where disabled access is required



Tap ware Licence

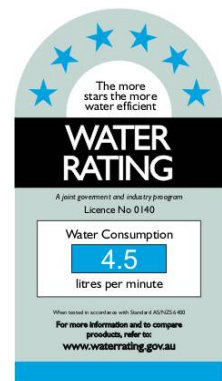

Rating for Easy Drink Tap



Due to continuous product research and development, the information contained herein is subject to change without notification.



Drinking Fountain Metro Dual

Wall Mounted

Specifications:

- Construction: Stainless Steel construction, no 4 satin finish. Unit is pre plumbed with button and bubbler.
- Water Supply: 15mm (½" BSP).
- Waste Connection: 40mm waste connection. Excess water can be drained to a rubble pit, a nearby garden or, with the Hepvo trap, it can be connected to grey water.
- Unit Fixing: The unit is supplied with a stainless steel wall mounting panel. Access panels provide secured access to plumbing.
- Disabled Access: Fixing height for the Disable Access Code AS 1428.2 is 700mm from the top of unit to finished floor level.

Models:

SPPL.DF.MD.WM

Code explanation:

- SPPL = Standard Product Plumbing
- DF = Drinking Fountain
- MD = Metro Dual
- WM = Wall mounted
- e.g.: for specification and ordering
- SPPL.DF.MD.WM

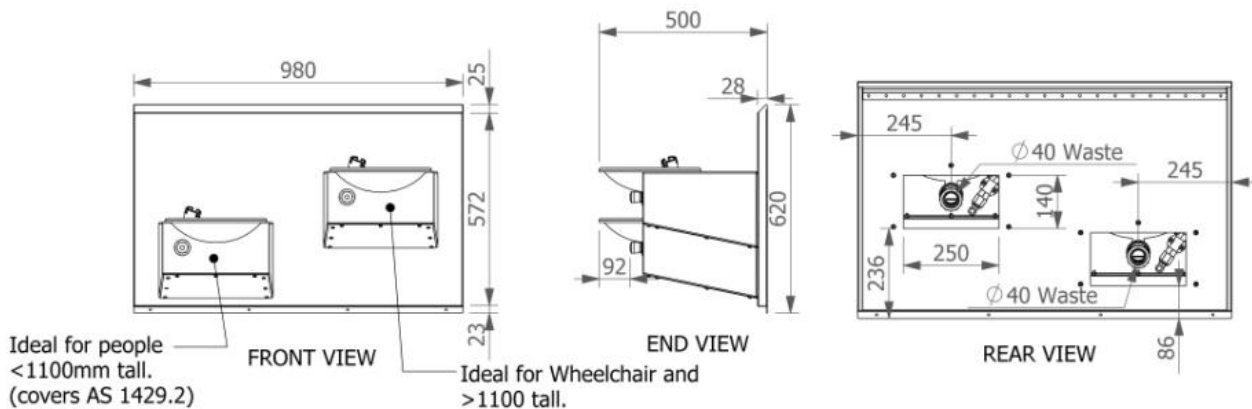
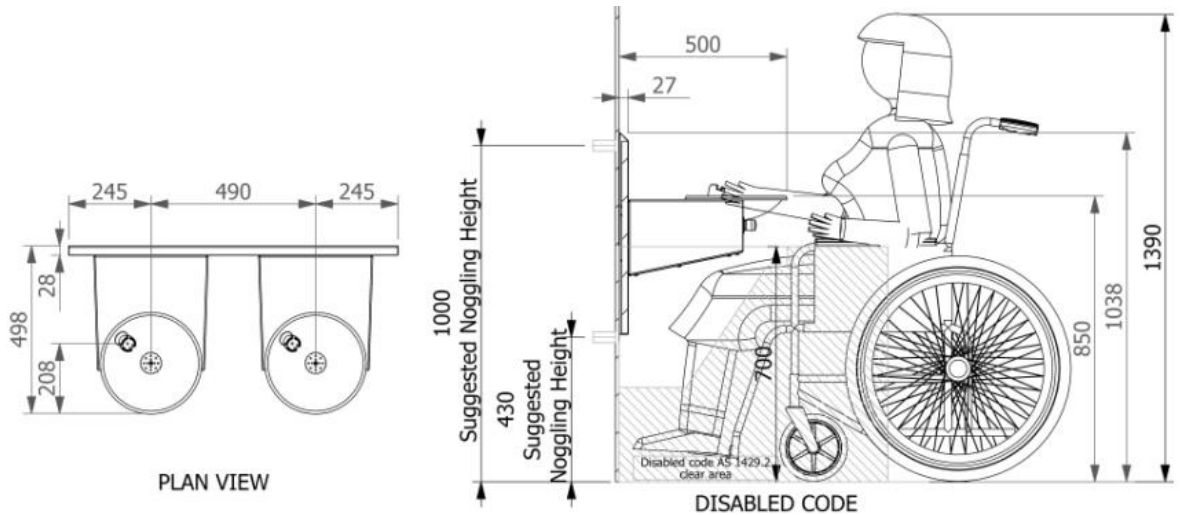

Model No.	Length (mm)	Width (mm)	Height (mm)
SPPL.DF.MD.WM	980	494	620

Due to continuous product research and development, the information contained herein is subject to change without notification.