

PLAN VIEW

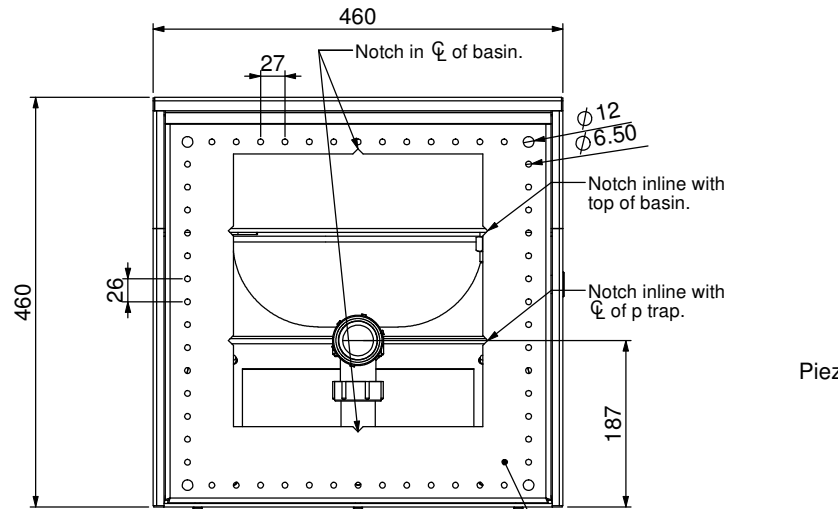

REAR VIEW

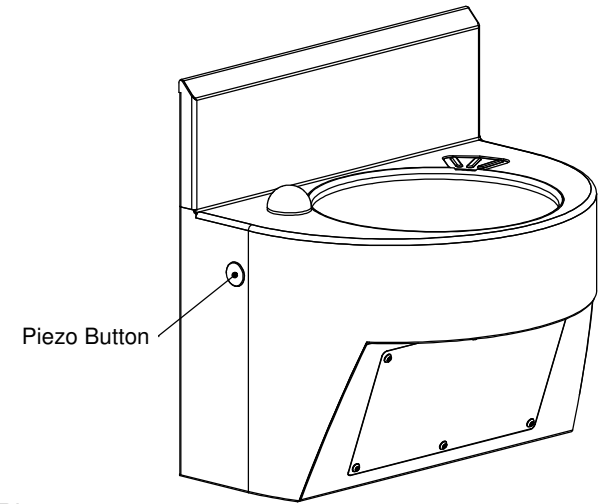

ISOMETRIC VIEW

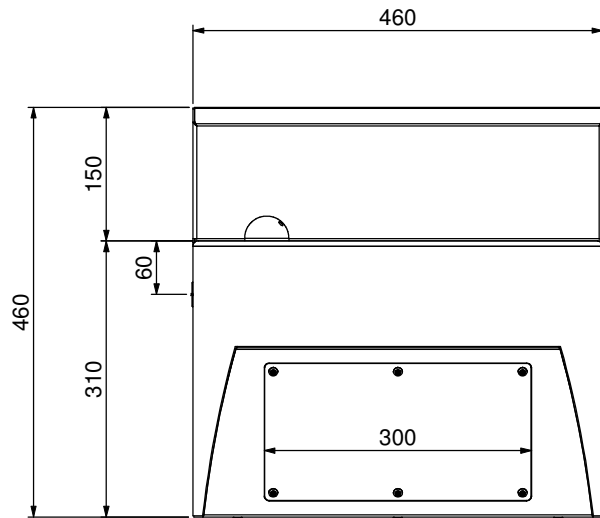

FRONT VIEW

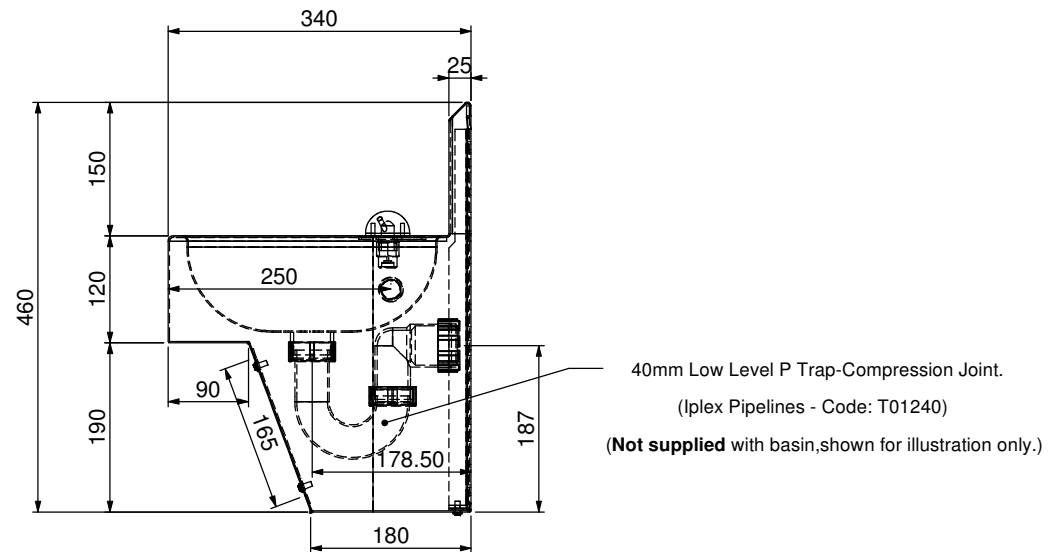

END VIEW

ALL STAINLESS STEEL PANELS ARE 1.5mm THICK.

STODDART
Manufacturing
TOM STODDART Pty Ltd ACN 009 690 251
215 Jackson Rd Sunnybank Hills Qld 4109
PO Box 420 Sunnybank Qld 4109
Phone (617) 3345 5011 Fax (617) 3344 1000
Email sunnybank@stoddart.com.au
Quality in stainless steel

Press:		Programmed by:		Date:	Punch:	Die:
PRODUCT: Wash Basin-Security-Round-2-WM						PART No: SPPL-WB-SR2-WM-FA-T340-VAR-A001
DRAWN	J Pickels	SIGNATURE	DATE	UNLESS OTHERWISE SPECIFIED: DIMENSIONS ARE IN MILLIMETERS		DESCRIPTION: General Drawing
APPVD			30/06/2009	MATERIAL:		DWG No: SPPL-WB-SR2-WM-FA-T340-VAR-D001
				THICKNESS:		REVISION
				FINISH:		A
DO NOT SCALE DRAWING		This drawing remains the property of Tom Stoddart Pty Ltd & cannot be reproduced without prior permission.				A3
						Sheet 1 of 9