

PLAN VIEW

Product Details

Waste : 101.6 ϕ mm S/S Tube
 Water Connection : 25.4 ϕ mm S/S Tube

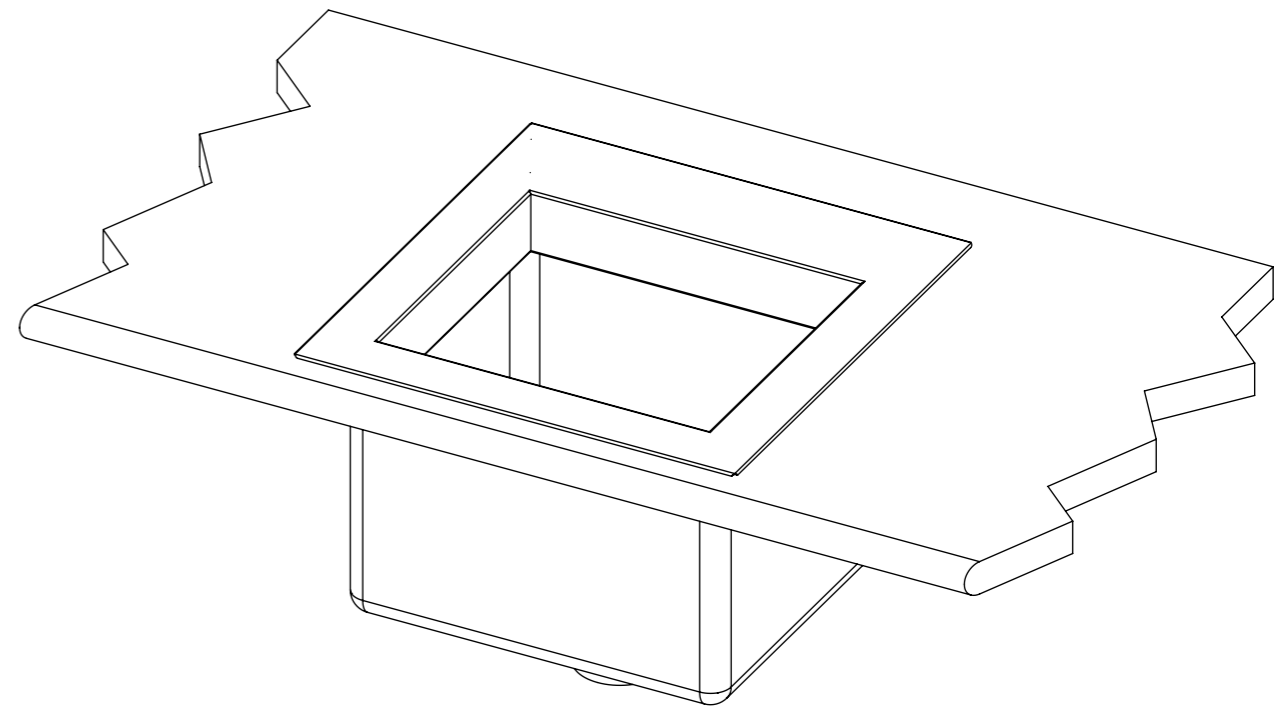

ISOMETRIC VIEW
(Flushing rim sink in benchtop)

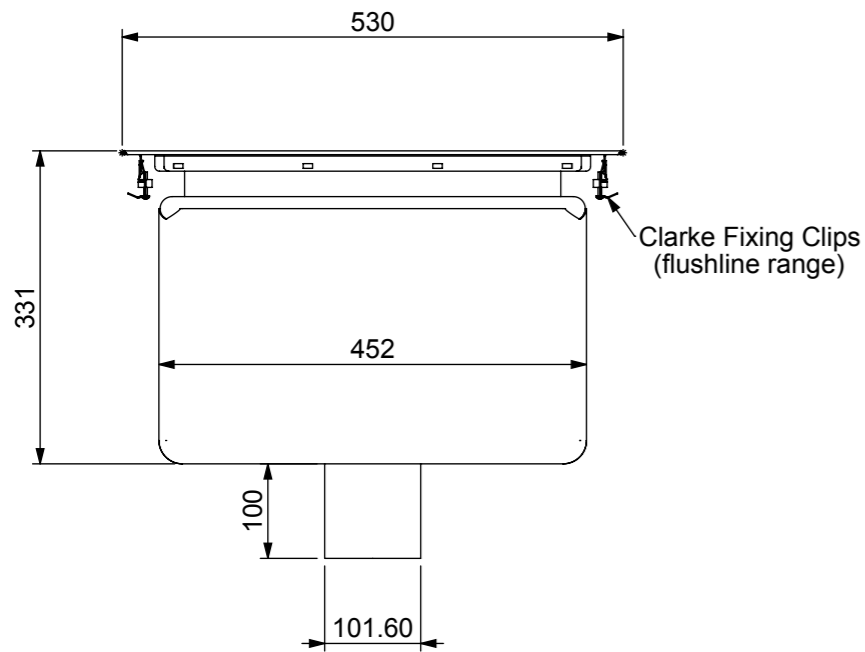

FRONT VIEW

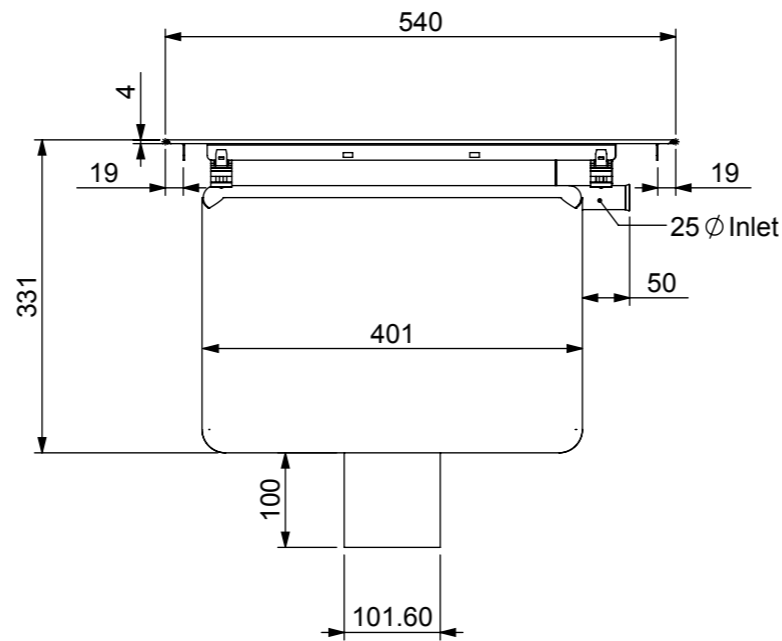

END VIEW

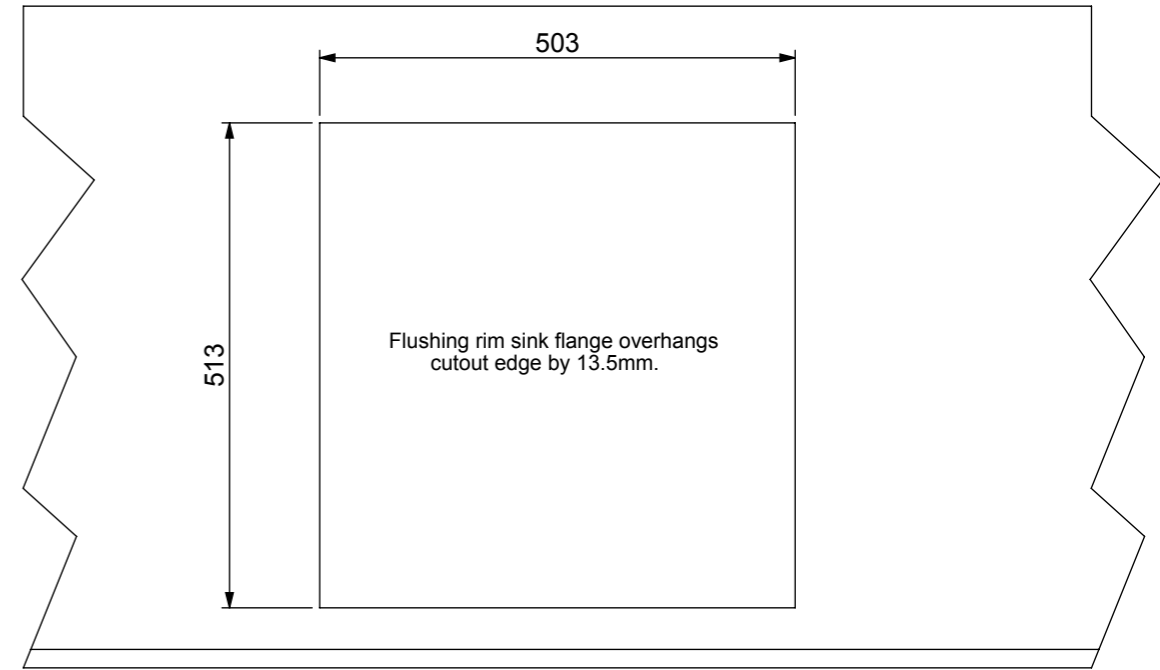

BENCHTOP CUTOUT SIZE

STODDART
 Manufacturing
 TOM STODDART Pty Ltd ACN 009 690 251
 215 Jackson Rd Sunnybank Hills Qld 4109
 PO Box 420 Sunnybank Qld 4109
 Phone (617) 3345 5011 Fax (617) 3344 1000
 Email sunnybank@stoddart.com.au
Quality in stainless steel

Press:		Programmed by:		Date:	Punch:	Die:
PRODUCT: Flushing Rim Sink Drop In (Rear)		PART No: SPPL FR DI R		DESCRIPTION: General Drawing		
DRAWN	J Pickels	SIGNATURE	DATE	UNLESS OTHERWISE SPECIFIED: DIMENSIONS ARE IN MILLIMETERS		
APPVD			6/03/2008	MATERIAL:		
				THICKNESS:		
				FINISH:		
DO NOT SCALE DRAWING		This drawing remains the property of Tom Stoddart Pty Ltd & cannot be reproduced without prior permission.			A3	Sheet 1 of 13
					DWG No: SPPL FR DI R	REVISION A