

PLAN VIEW

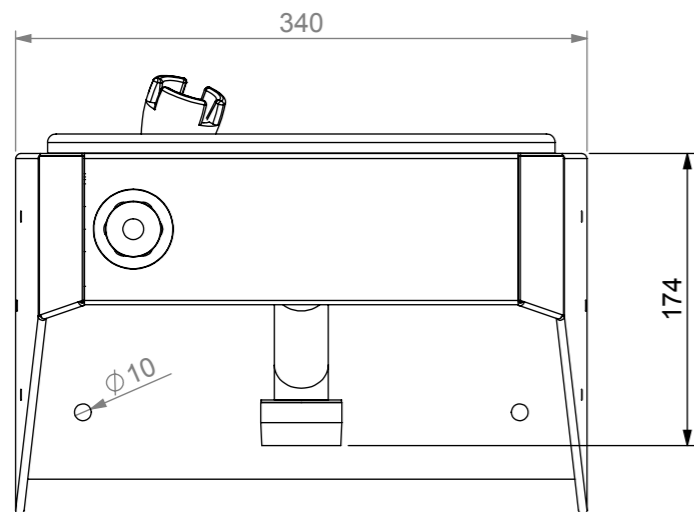

FRONT VIEW

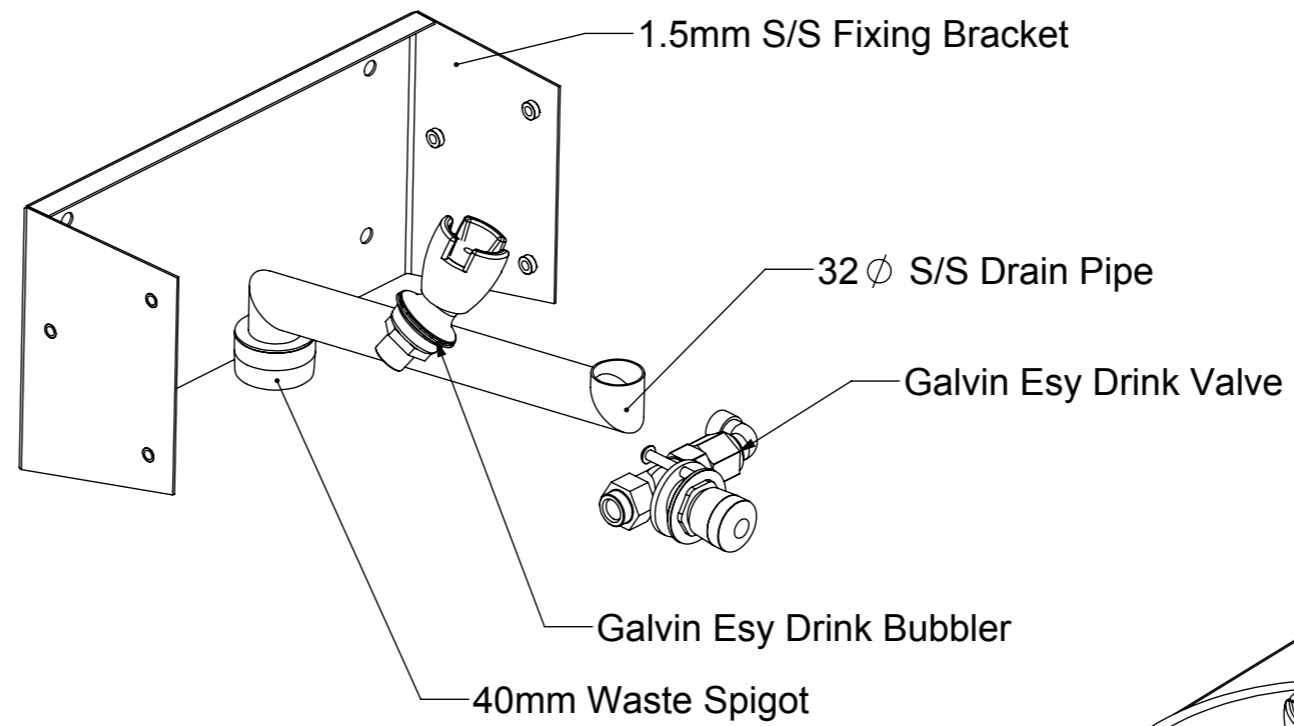

INTERNAL VIEW

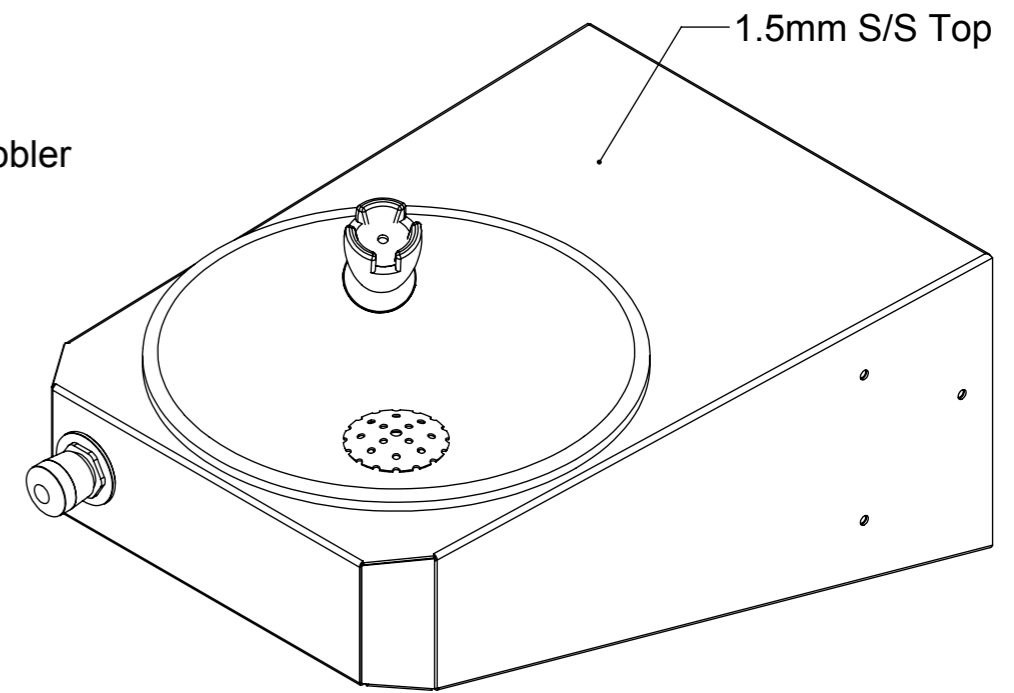

ISOMETRIC VIEW

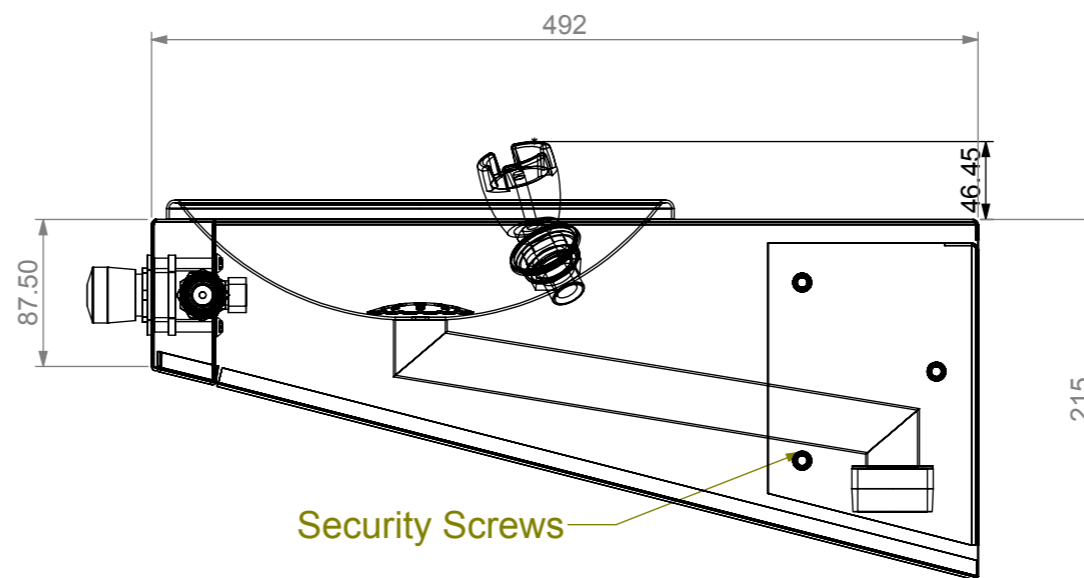

END VIEW



**STODDART
MANUFACTURING**
TOM STODDART Pty Ltd ACN 009 690 251
149 Jackson Rd Sunnybank Hills Qld 4109
PO Box 420 Sunnybank Qld 4109
Phone (617) 3345 5011 Fax (617) 3344 1000
Email sunnybank@stoddart.com.au
Quality in stainless steel

				PART No: SPPL-DF-MS-WM	
				DESCRIPTION: Disabled Drinking Fountain Wall Mounted	
				DWG No: SPPL-DF-MS-WM	
				Dwg. Issue 2	
DRAWN J Pickels		SIGNATURE		DATE 8/12/2008	
APPVD				UNLESS OTHERWISE SPECIFIED: DIMENSIONS ARE IN MILLIMETERS	
Weight: 6.49 kg		Surface Area: 1.13 M2		MATERIAL: THICKNESS: FINISH:	
DO NOT SCALE DRAWING		This drawing remains the property of Tom Stoddart Pty Ltd & cannot be reproduced without prior permission.			
		A3		Sheet 1 of 12	