

PLAN VIEW

Basin Body Panel : 1.5 304 NO.4 S/S

Access Panel : 1.5 304 NO.4 S/S

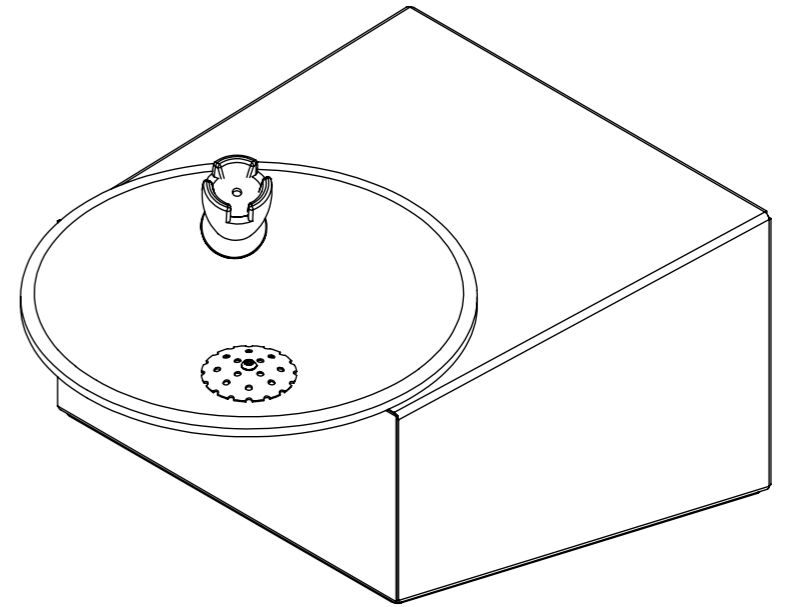

ISOMETRIC VIEW

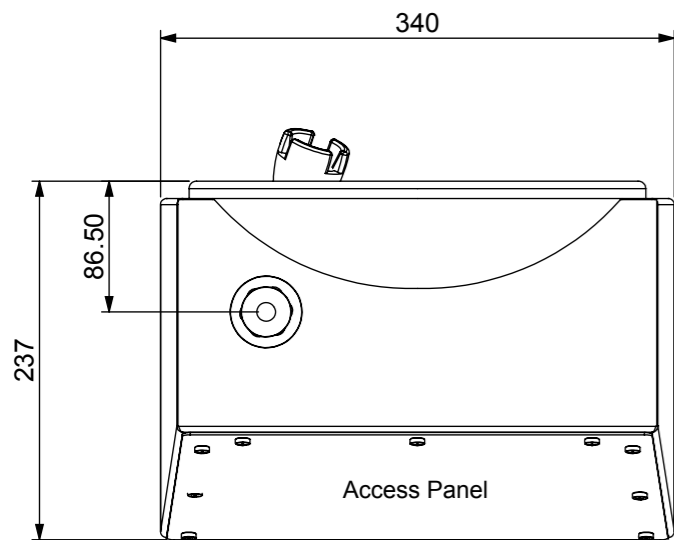

FRONT VIEW

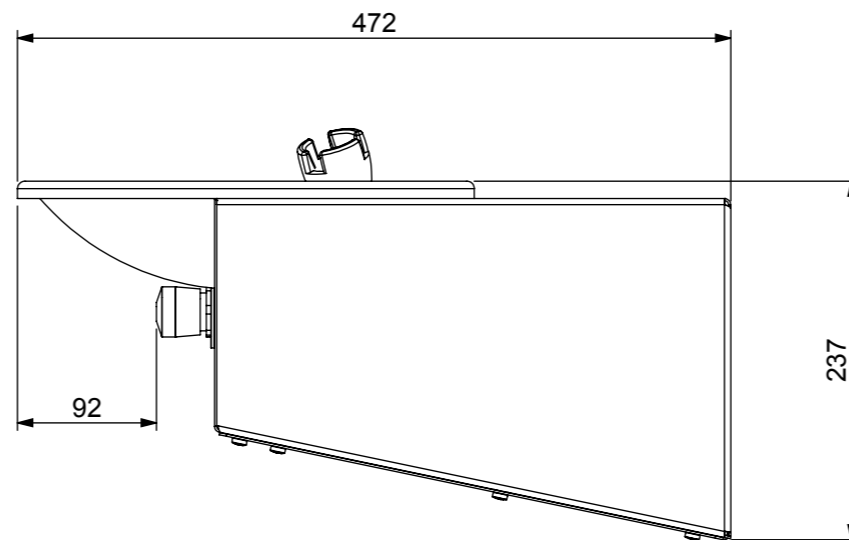

END VIEW

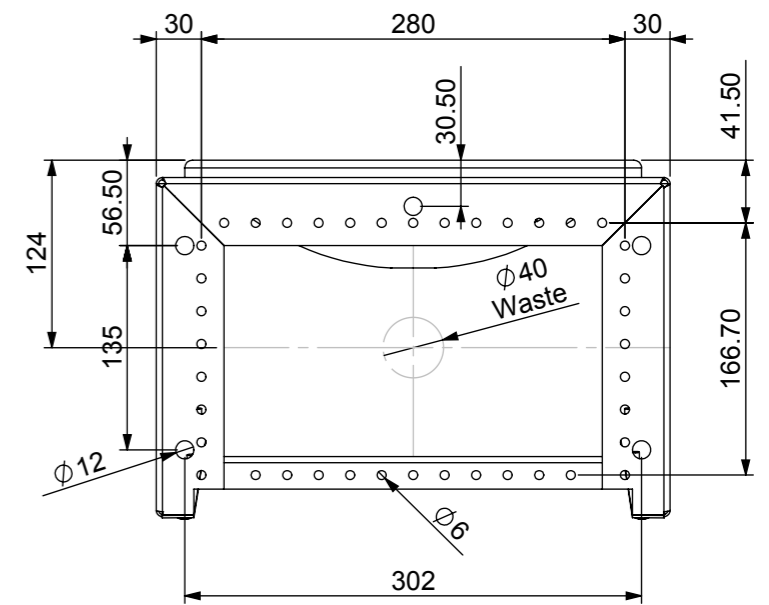

REAR VIEW

REVISION TABLE			
REV.	REVISED BY	DATE	REVISION DESCRIPTION
A		17/03/2011	For manufacture



**STODDART
MANUFACTURING**

TOM STODDART Pty Ltd ACN 009 690 251
215 Jackson Rd Sunnybank Hills Qld 4109
PO Box 420 Sunnybank Qld 4109
Phone (617) 3344 2444 Fax (617) 3345 6403
Email sunnybank@stoddart.com.au
Quality in stainless steel

<table border="1"> <tr> <th>NAME</th> <th>SIGNATURE</th> <th>DATE</th> <th>UNLESS OTHERWISE SPECIFIED: DIMENSIONS ARE IN MILLIMETERS</th> </tr> <tr> <td>J Pickels</td> <td></td> <td>8/04/2010</td> <td></td> </tr> <tr> <td colspan="3">APPVD</td> <td>MATERIAL:</td> </tr> <tr> <td colspan="3">Weight:</td> <td>THICKNESS:</td> </tr> <tr> <td colspan="3">Surface Area:</td> <td>FINISH:</td> </tr> </table>				NAME	SIGNATURE	DATE	UNLESS OTHERWISE SPECIFIED: DIMENSIONS ARE IN MILLIMETERS	J Pickels		8/04/2010		APPVD			MATERIAL:	Weight:			THICKNESS:	Surface Area:			FINISH:	PART No: SPPL-DF-M2-WM Rev A DESCRIPTION: Assembly Description	
NAME	SIGNATURE	DATE	UNLESS OTHERWISE SPECIFIED: DIMENSIONS ARE IN MILLIMETERS																						
J Pickels		8/04/2010																							
APPVD			MATERIAL:																						
Weight:			THICKNESS:																						
Surface Area:			FINISH:																						
DO NOT SCALE DRAWING				This drawing remains the property of Tom Stoddart Pty Ltd & cannot be reproduced without prior permission.																					
DWG No: SPPL-DF-M2-WM Rev A				Dwg. Issue 1																					
A3				Sheet 1 of 13																					