

PLAN VIEW

**Splashback Panel : 1.2 304 NO.4 S/S**  
**Basin Body Panel : 1.5 304 NO.4 S/S**  
**Access Panel : 1.2 304 NO.4 S/S**

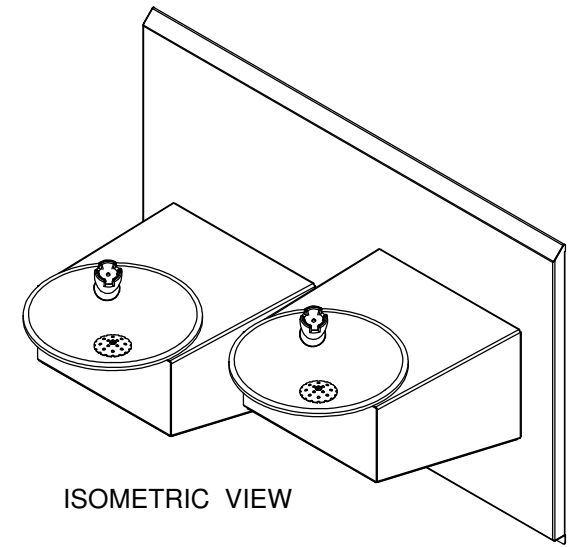

ISOMETRIC VIEW

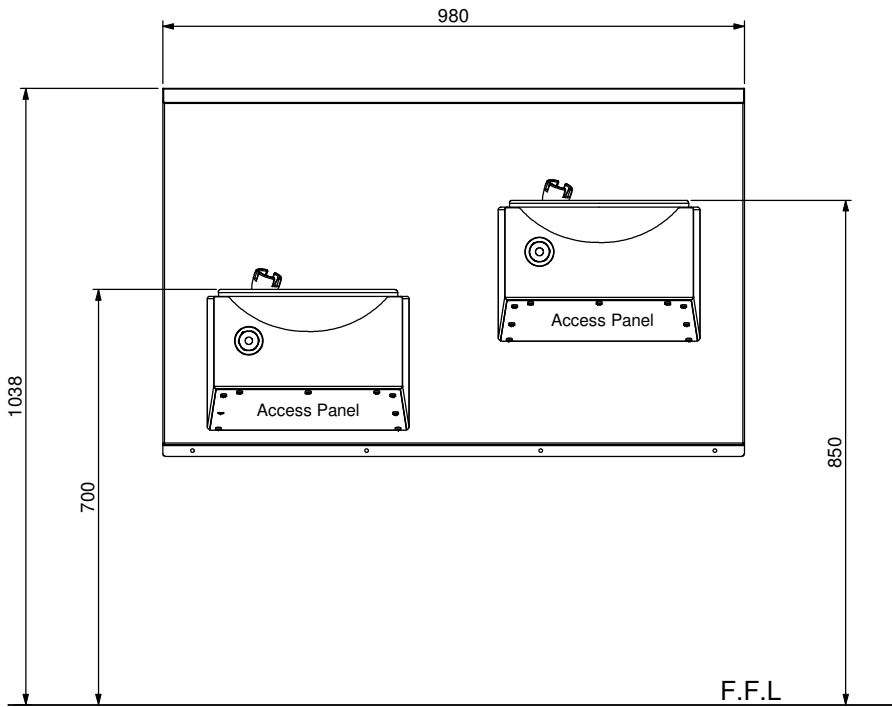

FRONT VIEW

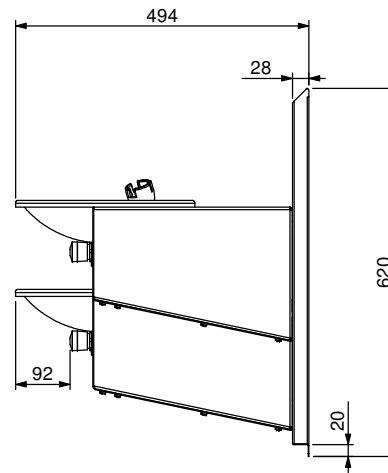

END VIEW

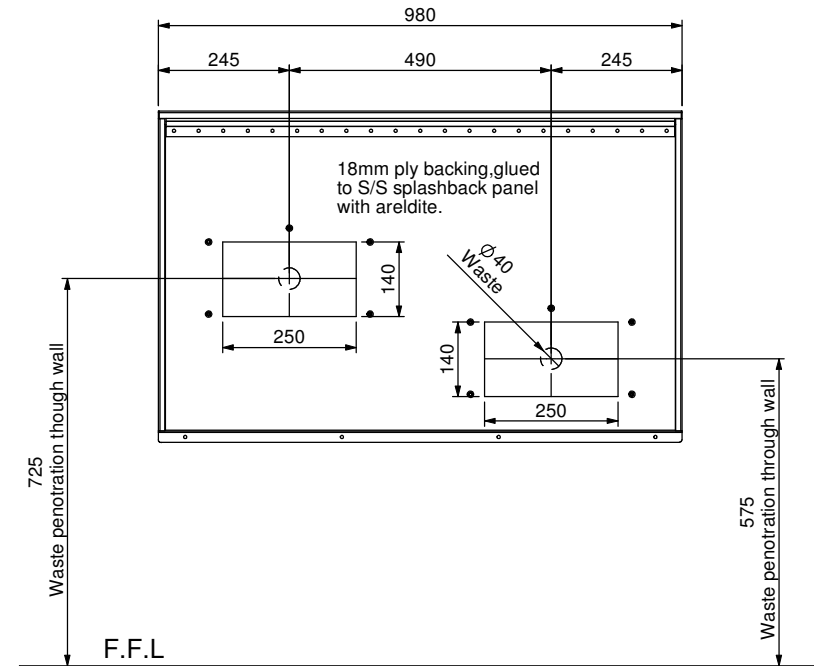

REAR VIEW

REVISION TABLE				
REV.	REVISED BY	DATE	REVISION DESCRIPTION	STATUS
A	J Pickels	08/04/2010	Never released to floor	
B	J Pickels	15/03/2011	Bubbler and valve changed, holes to basin body changed	For manufacture



**STODDART MANUFACTURING**  
 TOM STODDART Pty Ltd ACN 009 690 251  
 215 Jackson Rd Sunnybank Hills Qld 4109  
 PO Box 420 Sunnybank Qld 4109  
 Phone (617) 3344 2444 Fax (617) 3345 6403  
 Email sunnybank@stoddart.com.au  
*Quality in stainless steel*

DRAWN: J Pickels				DATE: 8/04/2010		UNLESS OTHERWISE SPECIFIED: DIMENSIONS ARE IN MILLIMETERS		PART No: <b>SPPL-DF-MD-WM Rev B</b>	
APPVD:				MATERIAL:		THICKNESS:		DESCRIPTION: Assembly Description	
Weight:				Surface Area:		FINISH:		DWG No: <b>SPPL-DF-MD-WM Rev B</b>	
DO NOT SCALE DRAWING				This drawing remains the property of Tom Stoddart Pty Ltd & cannot be reproduced without prior permission.				A3	
								Sheet 1 of 17	
								Dwg. Issue <b>1</b>	