

PLAN VIEW

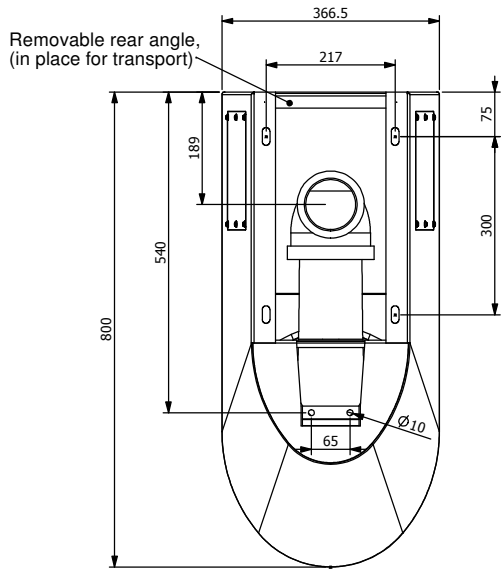

UNDERSIDE VIEW

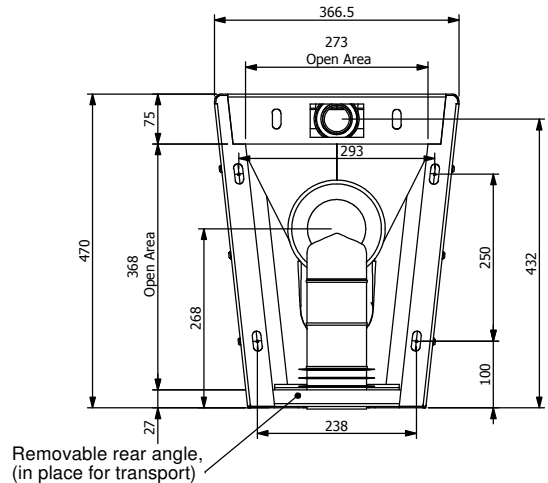

REAR VIEW

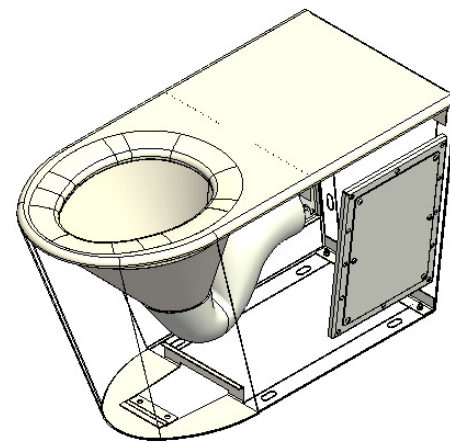

ISOMETRIC VIEW  
(Showing Base Fixing Lug)

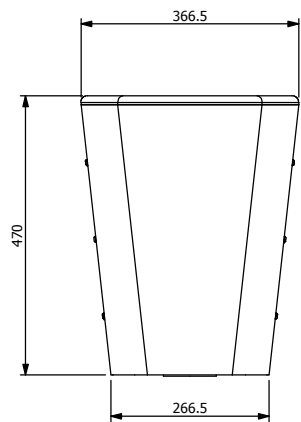

FRONT VIEW

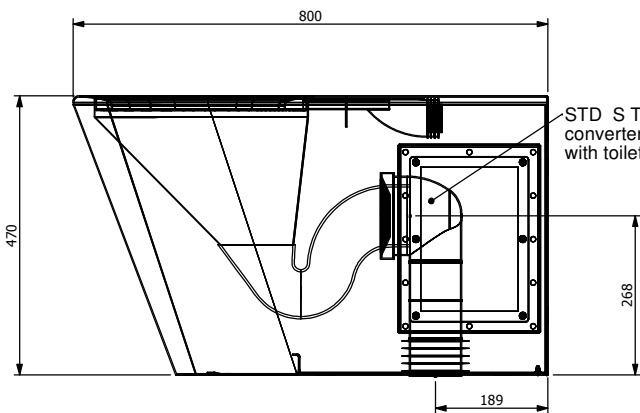

END VIEW

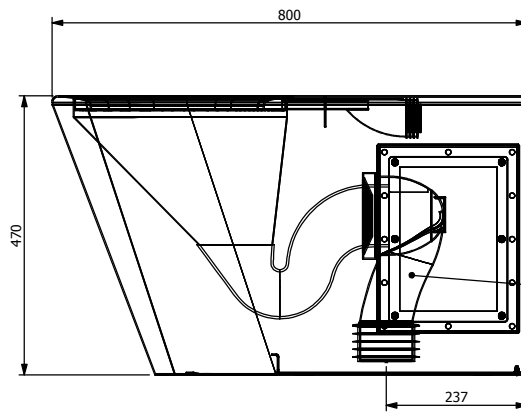

END VIEW

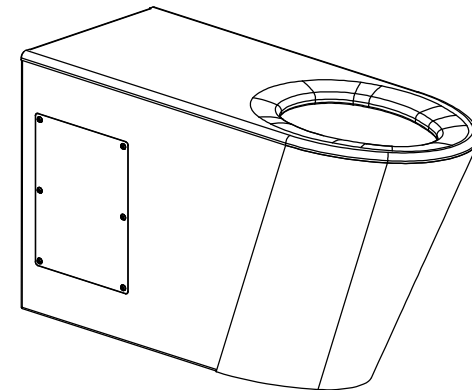

ISOMETRIC VIEW

| REVISION TABLE |            |            |   |
|----------------|------------|------------|---|
| REV.           | REVISED BY | DATE       | REVISION DESCRIPTION                          |
| A              |            | 29/06/2010 |   |
| B              | J Pickels  | 9/08/2011  | Parts changed,001,002,004,005,007,008,009,012 |



**STODDART MANUFACTURING**  
 TOM STODDART Pty Ltd ACN 009 690 251  
 149 Jackson Rd Sunnybank Hills Qld 4109  
 PO Box 420 Sunnybank Qld 4109  
 Phone (617) 3345 5011 Fax (617) 3344 1000  
 Email sunnybank@stoddart.com.au  
*Quality in stainless steel*

|                       |  |  |  |  |  |  |                        |               |
|-----------------------|--|--|--|--|--|--|------------------------|---------------|
| DRAWN J Pickels       |  |  |  | DATE 10/02/2010  | UNLESS OTHERWISE SPECIFIED:<br>DIMENSIONS ARE IN MILLIMETERS | PART No: <b>SPPL-TP-WF-3-D-S-BSA Rev B</b> |                        |               |
| APPVD                 |  |  |  | MATERIAL:  |  | DESCRIPTION: Stainless Toilet Pan          |                        |               |
| Weight: 26.40 kg      |  |  |  | THICKNESS:   | DWG No: <b>SPPL-TP-WF-3-D-S-BSA Rev B</b>                    |  | Dwg. Issue<br><b>1</b> |               |
| Surface Area: 3.67 M2 |  |  |  |  | FINISH:  |  |                        |               |
| DO NOT SCALE DRAWING  |  |  |  | This drawing remains the property of Tom Stoddart Pty Ltd & cannot be reproduced without prior permission. |  |  |                        | A3            |
|                       |  |  |  |  |  |  |                        | Sheet 1 of 17 |