

PLAN VIEW

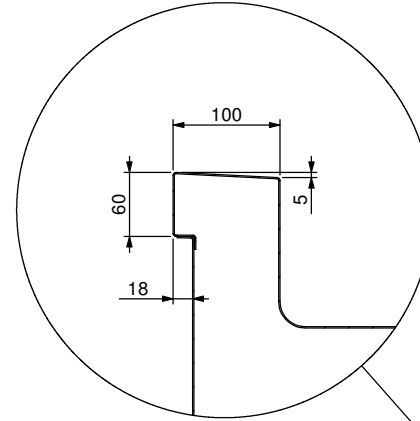

DETAIL B
SCALE 1 : 5

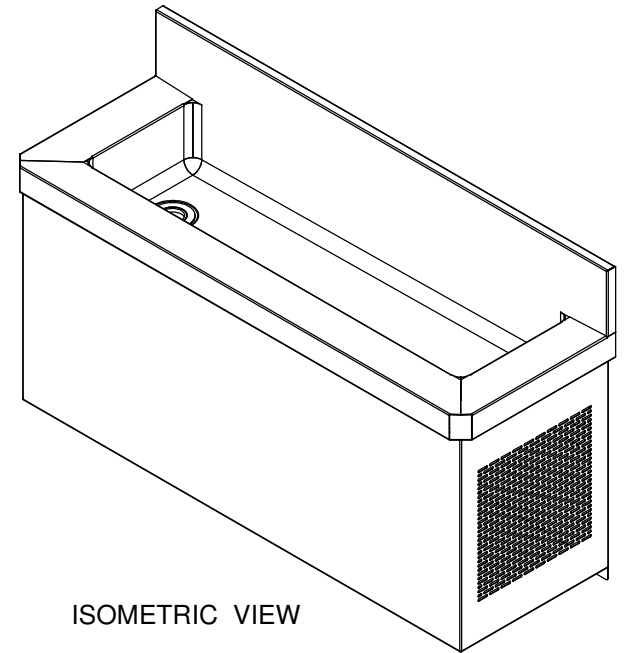

ISOMETRIC VIEW

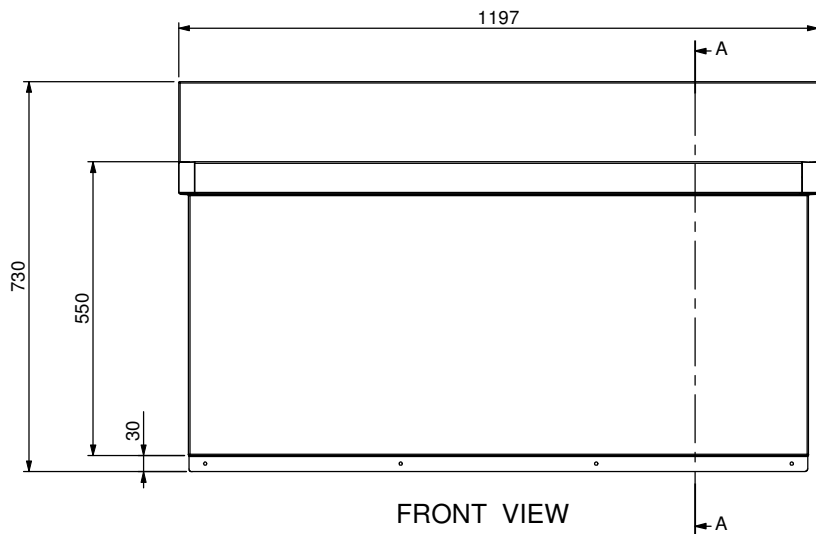

FRONT VIEW

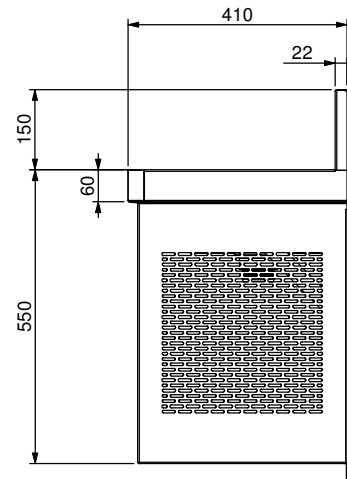

END VIEW

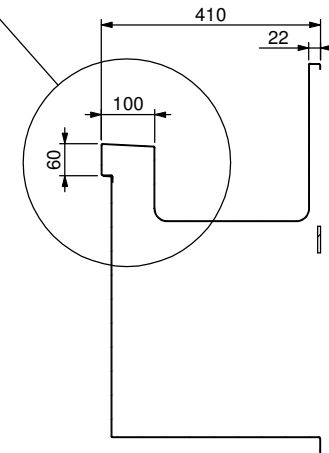

SECTION A-A

L/H WASTE SHOWN



**STODDART
MANUFACTURING**
TOM STODDART Pty Ltd ACN 009 690 251
149 Jackson Rd Sunnybank Hills Qld 4109
PO Box 420 Sunnybank Qld 4109
Phone (617) 3345 5011 Fax (617) 3344 1000
Email sunnybank@stoddart.com.au
Quality in stainless steel

				PART No: SPPL-DT-S5-L-P-1197-DA-VAR Rev A	
NAME	SIGNATURE	DATE	UNLESS OTHERWISE SPECIFIED: DIMENSIONS ARE IN MILLIMETERS		DESCRIPTION: L/H Drinking Trough
DRAWN J Pickels		15/12/2008			
APPVD			MATERIAL:		
Weight: 4.01 kg			THICKNESS:		
Surface Area: 5.76 M2			FINISH:		
DO NOT SCALE DRAWING	This drawing remains the property of Tom Stoddart Pty Ltd & cannot be reproduced without prior permission.				DWG No: SPPL-DT-S5-L-P-1197-DA-VAR Rev A
				A3	Sheet 1 of 13

Dwg. Issue
1